

1.22	ALLOY STEEL FIG. 1.3 & 1.4	STRUCTURAL STEEL FIG. 1.5
YIELD POINT	N/A	265 MPa
YIELD STRENGTH	450 MPa	N/A
UPPER YIELD POINT	N/A	280 MPa
LOWER YIELD POINT	N/A	265 MPa
MODULUS OF RESILIENCE	N/A	0.1855 MPa
ULTIMATE TENSILE STRENGTH	715 MPa	470 MPa
STRAIN AT FRACTURE	0.23	0.26
PER CENT ELONGATION	23%	26%

- 1.23 ASSUME:
1. PLANE SECTIONS NORMAL TO THE AXIS OF THE ROD REMAIN PLANE UNDER APPLICATION OF THE LOAD.
  2. SHEAR STRAINS VARY LINEARLY FROM THE LONGITUDINAL AXIS.
  3. HOOKE'S LAW APPLIES

EQUILIBRIUM:  $\sum M_x = 0$   
 $T = \int_A \rho T dA \quad (a)$

COMPATIBILITY:  
 $\gamma = \frac{\gamma_{max}}{r} \rho \quad (b)$

HOOKE'S LAW:  
 $T = G\gamma \quad (c)$

SUB (c) INTO (b) & THEN (b) INTO (a)

$$T = \frac{T_{max}}{r} \int_A \rho^2 dA$$

$$T = \frac{T_{max}}{r} J ; J = \int_A \rho^2 dA$$

$$\underline{\underline{T_{max} = \frac{Tr}{J} \text{ ON SURFACE}}}$$

$$\underline{\underline{T = \frac{Tr}{J} \text{ AT ANY } \rho \quad (d)}}$$

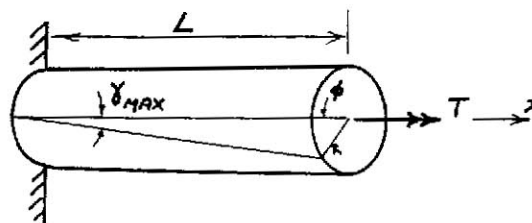
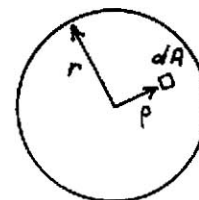

FROM GEOMETRY OF DEFORMATION:

$$\gamma_{max} = \frac{r\phi}{L} ; \gamma = \frac{\rho\phi}{L} \quad (e)$$

SUB (d) & (e) INTO (c)

$$\frac{Tr}{J} = G \left( \frac{\rho\phi}{L} \right)$$

$$\underline{\underline{\phi = \frac{TL}{GJ}}}$$

1.24 ASSUME: 1. PLANE SECTIONS NORMAL TO THE AXIS OF THE BAR REMAIN PLANE UNDER APPLICATION OF THE LOAD.  
2. HOOKE'S LAW APPLIES.

EQUILIBRIUM:

$$P = \sigma A \quad (a)$$

HOOKE'S LAW:

$$\sigma = E \epsilon \quad (c)$$

CONTINUITY:

$$\Delta L = \int_0^L \epsilon \, dx \quad (b)$$

GEOMETRY

$$A(x) = b(d_o - \frac{x}{L}(d_o - d_i)) \quad (d)$$

SUB (d) INTO (a)

$$\sigma = \frac{P}{b(d_o - \frac{x}{L}(d_o - d_i))} \quad (e)$$

SUB. (c) & (e) INTO (b):

$$\Delta L = \int_0^L \frac{P}{Eb} \left[ d_o - \frac{x}{L}(d_o - d_i) \right]^{-1} dx$$

$$\Delta L = \frac{PL}{Eb} \int_0^L \frac{dx}{d_o L - x(d_o - d_i)} = \frac{PL}{Eb} \left( \frac{1}{d_o - d_i} \right) \ln \frac{d_o}{d_i}$$

1.25

RODS:  $A_R = 4 \left( \frac{\pi}{4} 15^2 \right) = 706.9 \text{ mm}^2$

PIPE:  $A_P = \frac{\pi}{4} (100^2 - 90^2) = 1492 \text{ mm}^2$

AFTER ASSEMBLY:  $T_R = C_P = 4(65) = 260 \text{ kN}$

$$\sigma_R = \frac{4(65000)}{706.9} = 367.8 \text{ MPa}$$

$$\sigma_P = \frac{-4(65000)}{1492} = -174.3 \text{ MPa}$$

AFTER PRESSURE IS APPLIED:

EQUILIBRIUM:

$$P \left( \frac{\pi}{4} 90^2 \right) = \Delta T_R + \Delta C_P \quad (a)$$

COMPATIBILITY:

$$\Delta L_R = \Delta L_P; \frac{\Delta T_R L}{A_R E} = \frac{\Delta C_P L}{A_P E} \quad (b)$$

LEAKAGE REQUIREMENT:

$$\Delta C_P = 260 \text{ kN} \quad (c)$$

SUB (c) INTO (b):

$$\Delta T_R = 123.2 \text{ kN} \quad (d)$$

SUB (c) & (d) INTO (a)

$$P = 60.23 \text{ MPa}$$

$$\Delta \sigma_R = \frac{123200}{706.9} = 174.3 \text{ MPa}$$

$$\sigma_{R(FINAL)} = 542.1 \text{ MPa}$$

1.26

(a) Figure a shows the bars subjected to force P. Figure b shows the free-body diagrams of the steel bar, the aluminum bar, and point A. By the free-body diagram of point A,

$$P = P_s + P_a \quad (a)$$

By Eq. (1.2) and Figs. a and b,

$$\delta_a = \frac{P_s L_s}{E_s A_s} = \frac{P_a L_a}{E_a A_a} \quad (b)$$

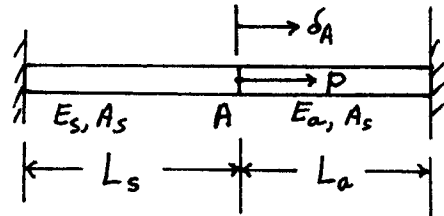
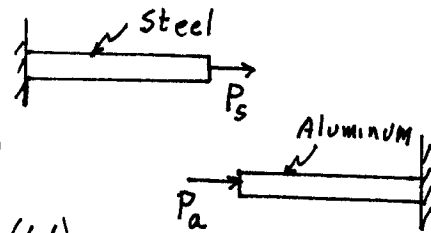

Figure a

By Eqs. (a) and (b),

$$P_s = \frac{P_a E_s A_s L_a}{E_a A_a L_s} = \frac{(P - P_s)(E_s A_s L_a)}{E_a A_a L_s}$$



Solving this equation for P\_s, we find

$$P_s = \frac{P E_s A_s L_a}{E_s A_s L_a + E_a A_a L_s}. \text{ Hence, by Eq. (1.1),}$$

the stress in the steel bar is

$$\sigma_s = \frac{P_s}{A_s} = \frac{P}{A_s} \left( \frac{E_s A_s L_a}{E_s A_s L_a + E_a A_a L_s} \right)$$

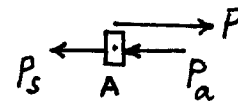

Figure b

Similarly, by Eqs. (a) and (b),

$$P_a = \frac{P_s E_a A_a L_s}{E_s A_s L_a} = \frac{(P - P_a)(E_a A_a L_s)}{E_s A_s L_a}$$

or

$$P_a = \frac{P E_a A_a L_s}{E_s A_s L_a + E_a A_a L_s}$$

Hence, the stress in the aluminum bar is

$$\sigma_a = \frac{P}{A_a} \left( \frac{E_a A_a L_s}{E_s A_s L_a + E_a A_a L_s} \right)$$

(cont.)

1.26 cont.

(b) When the left wall is displaced to the right by an amount  $\delta$ , the point A is displaced to the right by an amount  $\delta_A$  (Fig. c).

By Eq. (1.2) and Fig. c,

$$\delta_A = \frac{FL_a}{E_a A_a} \quad (a)$$

and

$$\delta - \delta_A = \frac{FL_s}{E_s A_s} \quad (b)$$

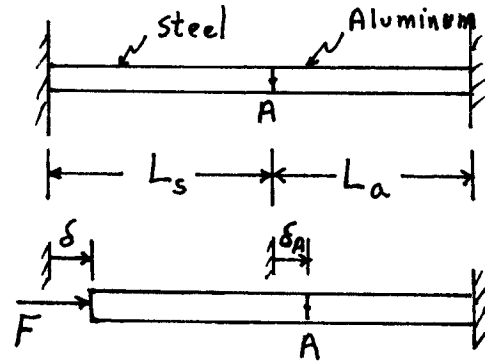

Figure c

By Eqs. (a) and (b),

$$\delta = \delta_A + \frac{FL_s}{E_s A_s} = F \left( \frac{L_a}{E_a A_a} + \frac{L_s}{E_s A_s} \right)$$

or

$$F = \frac{\delta E_a A_a E_s A_s}{E_s A_s L_a + E_a A_a L_s}$$

Hence, by Eq. (1.1), the stress in the steel bar is

$$\sigma_s = \frac{F}{A_s} = \frac{\delta E_a A_a E_s}{E_s A_s L_a + E_a A_a L_s}$$

and the stress in the aluminum bar is

$$\sigma_a = \frac{F}{A_a} = \frac{\delta E_a E_s A_s}{E_s A_s L_a + E_a A_a L_s}$$

1.27

(a) Consider the free-body diagram of a cable (Fig. a). By equilibrium,

$$\sum F_y = T - W = 0$$

$$W = AL\rho g, \quad g = \text{acceleration of gravity}$$

$$A = \pi D^2/4$$

Therefore,

$$T = AL\rho g \quad (a)$$

So the maximum stress in the cable is

$$\sigma_{\max} = \frac{T}{A} = L\rho g \quad (b)$$

For the steel cable, by Eq. (b),

$$\sigma_{\max} = \frac{1}{10} \sigma_u = \frac{1030}{10} \text{ MPa} = L(7920)(9.81)$$

or

$$L = 1325.7 \text{ m} \quad (c)$$

Similarly for the aluminum cable

$$\sigma_{\max} = \frac{1}{10} \sigma_u = \frac{570}{10} \text{ MPa} = L(2770)(9.81)$$

or

$$L = 2097.6 \text{ m} \quad (d)$$

Consequently, the aluminum cable can be longer before exceeding a stress greater than  $\frac{1}{10} \sigma_u$

(b) For a cable of length  $L$  subjected to a load  $P$  at its end, the elongation  $\delta$  is [see Eq. (1.3)]

$$\delta = \frac{\sigma L}{E} \quad (e)$$

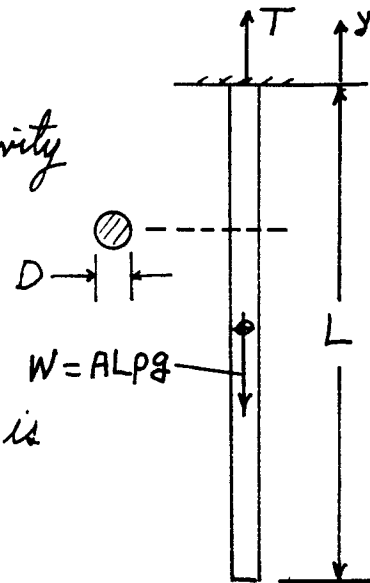

Figure a

(cont.)

1.27 Cont. Now consider the elongation of an element of length  $dx$  cut from the cable (Fig. b). For an element of length  $dx$ , the elongation  $d\delta$  is, by Eq. (e),

$$d\delta = \frac{\sigma}{E} dx = \frac{1}{E} \left( \frac{A \rho g x}{A} \right) dx \quad (f)$$

where  $A$  is the cross-sectional area of the cable and  $A \rho g x$  is the weight of the part of the cable below the cross section at distance  $x$  from the lower end.

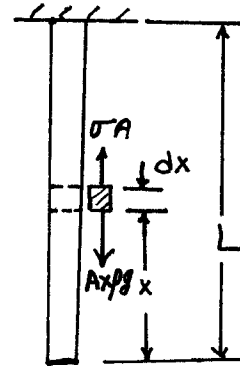

Figure b

Integration of Eq. (f) from  $x=0$  to  $x=L$  yields the total elongation  $\Delta$  of the cable as

$$\Delta = \frac{1}{2} \frac{AL^2 \rho g}{EA} = \frac{1}{2} \frac{WL}{EA} \quad (g)$$

where  $W = AL \rho g$  is the weight of the cable. Equations (g) and (1.2) show that the elongation of the cable due to its weight is equal to the elongation due to a load equal to half its weight applied at its end.

For a steel cable with  $\sigma = \frac{1}{10} \sigma_u$ ,  $L = 1325.7$  m, and Eq. (g) yields

$$\Delta = \frac{1}{2} (1325.7)^2 (7920)(9.81) / (193 \times 10^9) = 0.354 \text{ m}$$

For an aluminum cable with  $\sigma = \frac{1}{10} \sigma_u$ ,  $L = 2097.6$  m, and

$$\Delta = \frac{1}{2} (2097.6)^2 (2770)(9.81) / (72 \times 10^9) = 0.830 \text{ m}$$

(c) By Eq. (a), the tension at the top of the cable (Fig. a) due to the weight is  $AL \rho g$ . The tension at the top of the cable due to a load  $P$  applied at

(Cont.)

1.27 cont.

is  $P$ . So, the total tension is  $P + AL\rho g$ .  
Therefore, the maximum stress in the cable is

$$\sigma_{\max} = \frac{1}{A}(P + AL\rho g) = \frac{P}{A} + L\rho g \quad (h)$$

For  $\sigma_{\max} = \frac{1}{5}\sigma_u$ ,  $L = 1000$  m and  $D = 0.075$  m, Eq. (h) yields

For a steel cable:  $P = 566.8$  kN

For an aluminum cable:  $P = 383.6$  kN

The steel cable can lower a cage 1.478 times as heavy as an aluminum cable.

1.28

By Eq. (1.4), with  $J = \pi d^4/32$  and  $\rho = d/2$ , we obtain at  $\tau = 30$  MPa,

$$30 \text{ MPa} = \frac{16T}{\pi d^3} \quad (a)$$

and by Eq. (1.5), with  $\psi/L = 0.005$  rad/m,

$$0.005 \text{ rad/m} = \frac{32T}{G\pi d^4} \quad (b)$$

Assume that the maximum shear stress and the maximum angle of twist occur simultaneously.

Then, by Eqs. (a) and (b)

$$T = \frac{(30 \times 10^6)\pi d^3}{16} = \frac{(0.005)(77 \times 10^9)\pi d^4}{32}$$

or  $d = 0.1558$  m. For  $d < 0.1558$  m, Eq. (b) yields the smallest twisting moment  $T$ ; that is, the maximum angle of twist occurs before the maximum shear stress.

1.29

(a) By Fig. a, the area  $A$  of the cross section of the beam is

$$A = (6.5)(200 + 300) = 3250 \text{ mm}^2$$

and

$$A\bar{y} = (6.5)(300)(150) + (6.5)(200)(303.25) = 686725 \text{ mm}^3$$

or  $\bar{y} = 211.3 \text{ mm}$  (a)

(b) By Fig. b, the support reactions at A and B are determined by the equations

$$\sum F_y = A + B - 21 - (10)(3) = 0 \quad (b)$$

$$\sum M_A = 3B + (21)(1) - (10)(3)(1.5) = 0$$

The solution of Eqs. (b) is

$$A = 43 \text{ kN}, B = 8 \text{ kN} \quad (c)$$

With Fig. (b) and Eqs. (c), the shear and moment diagrams may be drawn (Fig. c).

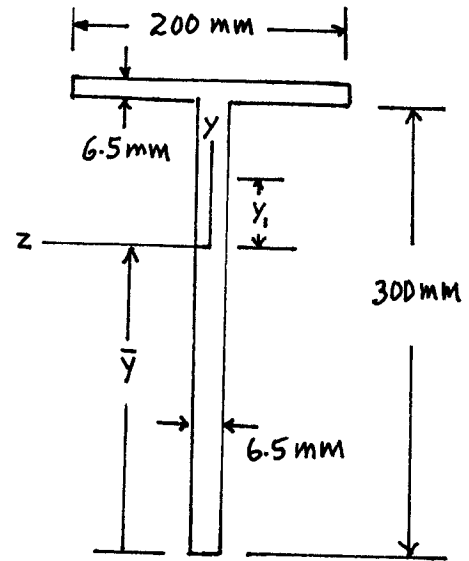

Figure a

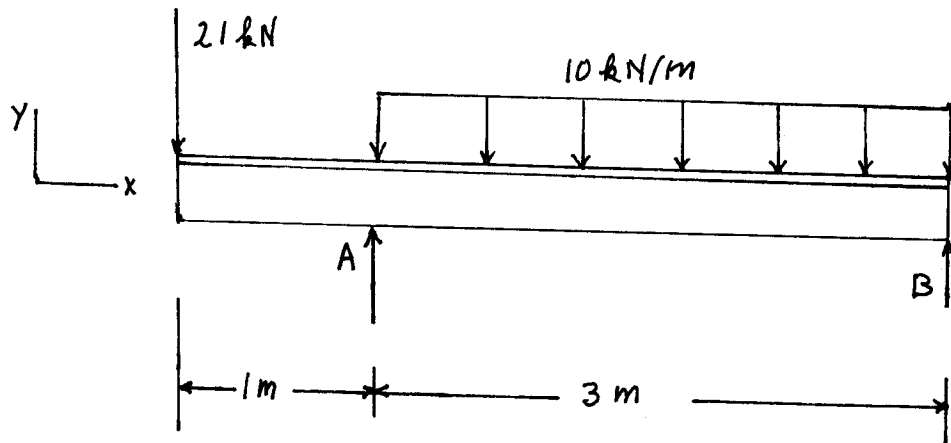

Figure b

(cont.)



1.29 cont.

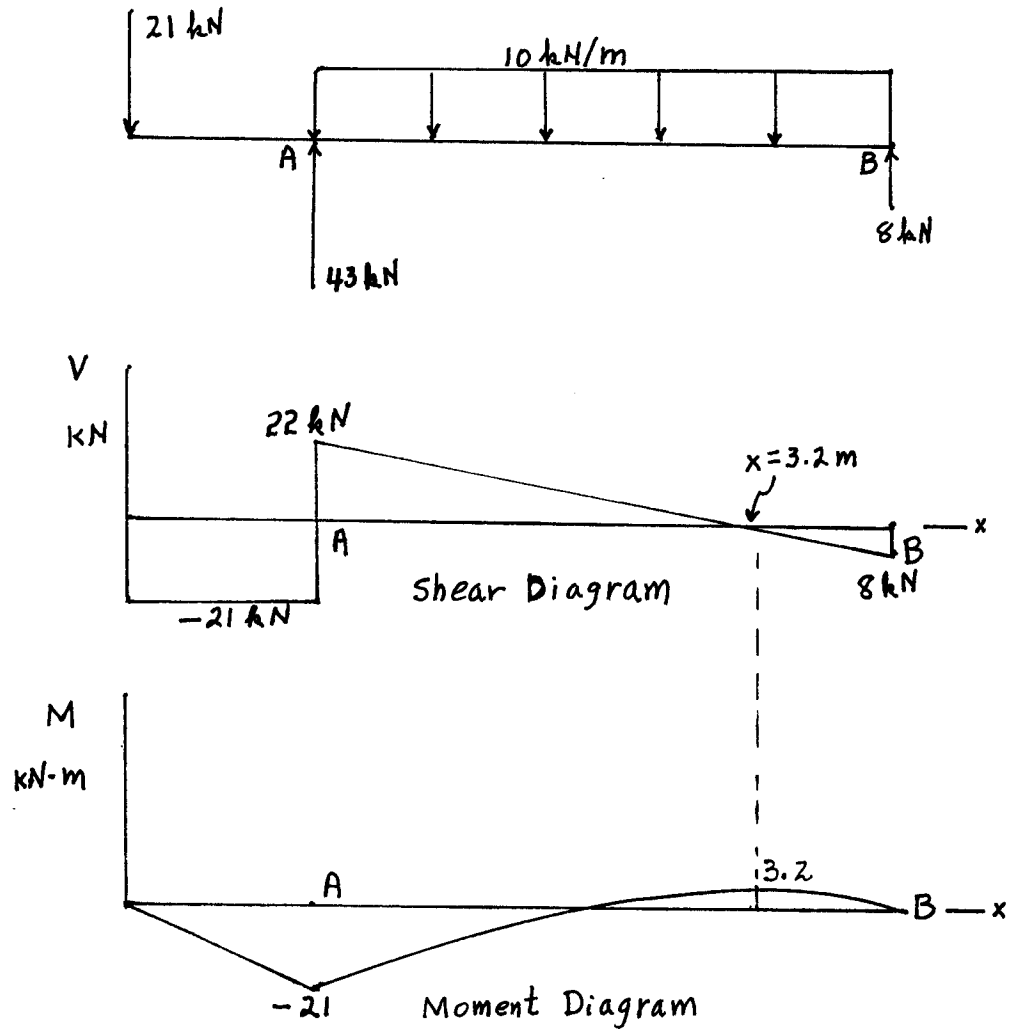

Figure c

1.30

By Fig. a, the moment of the cross-sectional area above  $y_1$ , with respect to the  $z$  axis is

$$Q = \int_{211.3}^{95.2} y dA = (6.5) \left[ (88.7 - y_1) \frac{(88.7 + y_1)}{2} + (200)(6.5)(91.95) \right]$$

or  $Q = 3.25(7867.7 - y_1^2) + 119535 \text{ [mm}^3\text{]} \text{ (a)}$

By the shear diagram of the beam (Fig. b), the maximum shear occurs at section A and is  $V = 22 \text{ kN}$ .

The area moment of inertia of the cross section of the T-beam is  $I_z = 32.948 \times 10^6 \text{ mm}^4$ . So, above the horizontal centroidal axis  $z$ , by Eqs. (1.9) and (a), the stress in the web is

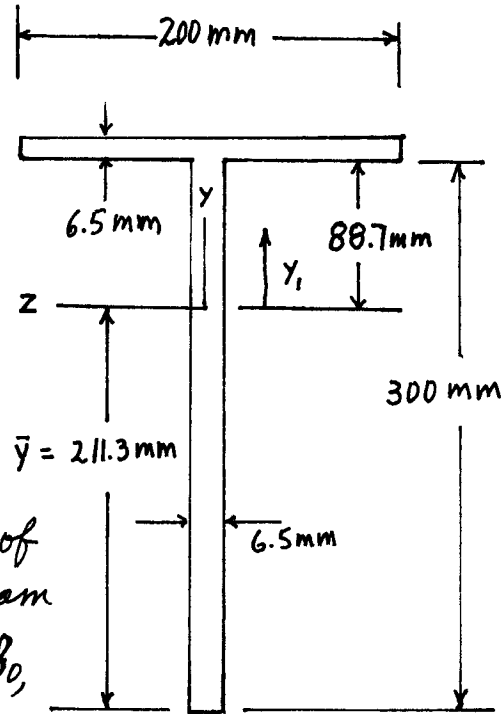

Figure a

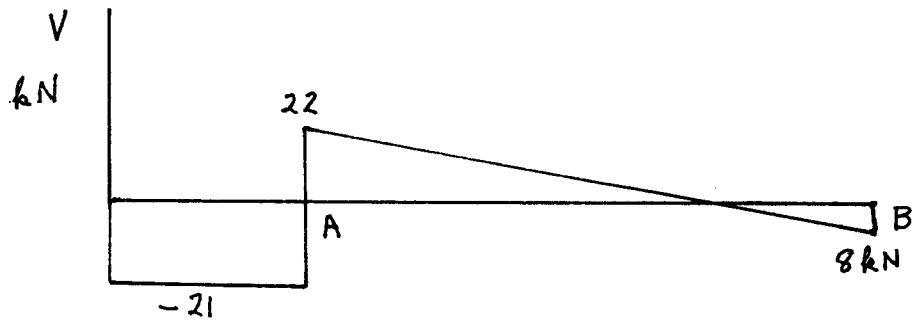

Figure b

$$\tau = \frac{VQ}{Ib} = \frac{(22) [3.25(7867.7 - y_1^2) + 119535]}{(32.948 \times 10^6)(6.5)} \text{ [N}\cdot\text{mm}^{-2}\text{]} \text{ (b)}$$

(cont.)

1.30 cont.

By Eq.(b),

$$\tau = 14.906 \text{ MPa for } y_1 = 0 \quad (c)$$

$$\tau = 12.279 \text{ MPa for } y_1 = 88.7 \text{ mm} \quad (d)$$

Below the horizontal centroidal axis  $z$  (Fig. c),

$$Q = (6.5)(211.3 - y_1)\left(\frac{211.3 + y_1}{2}\right) = 3.25(211.3^2 - y_1^2) \quad (e)$$

For  $y_1 = 0$ , Eq.(e) yields  $Q = 145105 \text{ mm}^3$ , and therefore,

$$\tau = \frac{VQ}{Ib} = \frac{(22)(145105)}{(32.948 \times 10^6)(6.5)} = 14.906 \text{ MPa}$$

as given previously [Eq.(c)].

For  $y_1 = 211.3$ ,  $Q = 0$  and  $\tau = 0$ . Hence, the maximum shear stress is  $\tau_{\max} = 14.906 \text{ MPa}$  at section A on the centroidal axis  $z$ . The minimum shear stress is  $\tau_{\min} = 0$  at the bottom of the web.

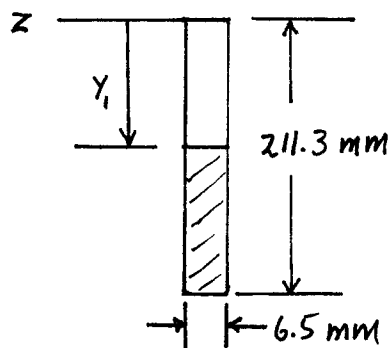

Figure c

1.31

The stress - strain curve is shown in Fig. a.

By Fig. a, the ultimate strength is  $\sigma_u \approx 665$  MPa since each rectangular box under the stress - strain curve represents  $(100)(0.05) = 5$  MN.m/m<sup>3</sup> of energy and we estimate that there are approximately 29.5 boxes under the stress - strain curve, we find

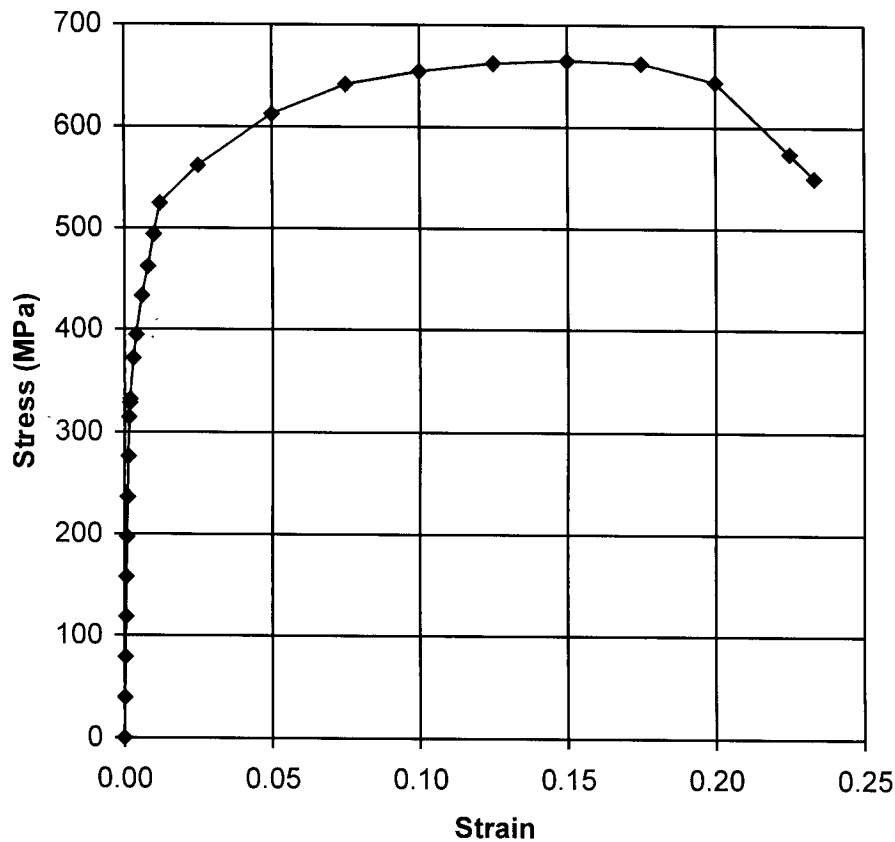

Figure a

that the modulus of toughness is

$$U_F = (5)(29.5) = 147.5 \text{ MN}\cdot\text{m}/\text{m}^3.$$

By numerical integration,

$$U_F = 144.2 \text{ MN}\cdot\text{m}/\text{m}^3$$

1.32

Extending the straight line portion of the stress-strain curve (Fig. a), we see that the slope of the line is

$$E = \frac{400}{.002} = 200 \text{ GPa.}$$

also, by Fig. a,

$$\sigma_{ys} = 395 \text{ MPa and } \sigma_{PL} = 315 \text{ MPa}$$

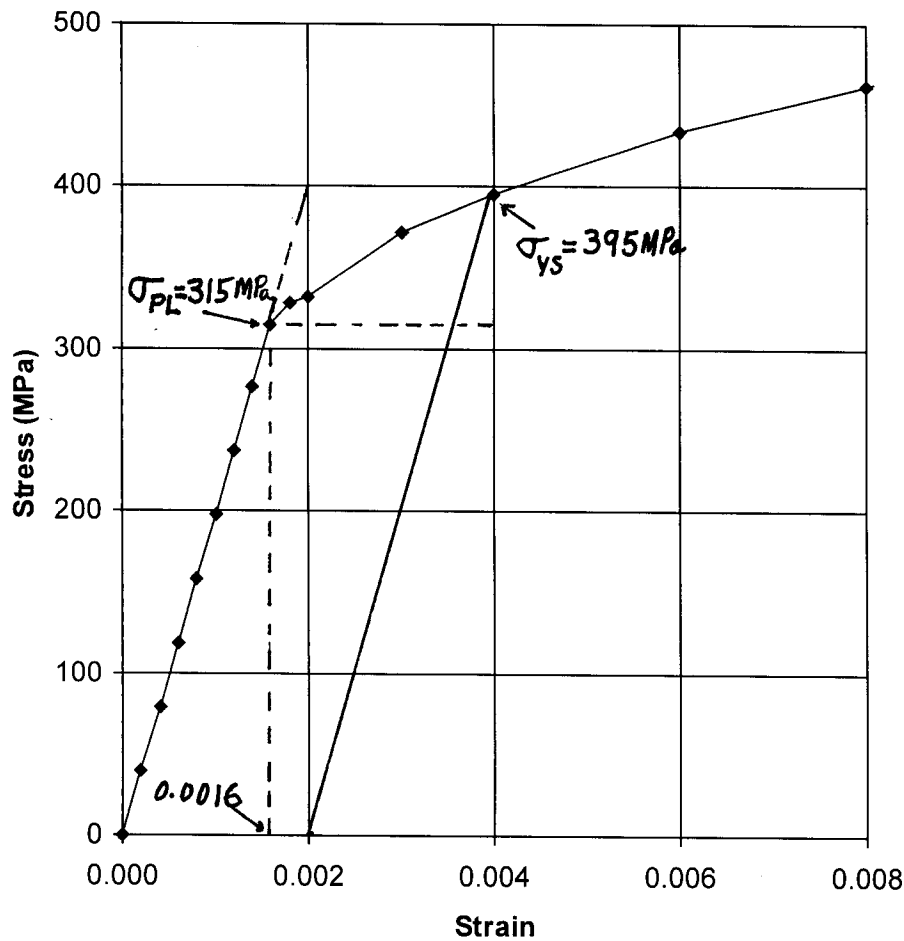

Figure a

The area under the stress-strain curve to the yield strength is approximately (see Fig. a)

$$\text{Area} = \frac{1}{2}(315)(0.0016) + (315)(0.004 - 0.0016) + \frac{1}{2}(395 - 315)(0.004 - 0.0016)$$

or,

$$\text{Modulus of Resilience} = 1.104 \text{ MN}\cdot\text{m/m}^3$$

1.33

The area of the test specimen is

$$A = \pi D^2/4 = \pi (20)^2/4 = 314.16 \text{ mm}^2$$

The stress at a load  $P = 75.4 \text{ kN}$  is

$$\sigma = \frac{P}{A} = 240 \text{ MPa} \quad (a)$$

The strain of the specimen is

$$\epsilon = \frac{\text{elongation}}{\text{gage length}} = \frac{0.330}{100} = 0.0033 \quad (b)$$

By Eqs. (a) and (b), the modulus of elasticity is

$$E = \frac{\sigma}{\epsilon} = 72.73 \text{ GPa}$$

The radial strain in the bar at a load of  $75.4 \text{ kN}$  is

$$\epsilon_r = \frac{19.978 - 20.0}{20} = -0.0011 \quad (c)$$

By Eqs. (b) and (c), the Poisson ratio is

$$\nu = -\frac{\epsilon_r}{\epsilon} = 0.33$$

Since the load and elongation are proportional up to  $P = 75.4 \text{ kN}$ , the proportional limit is

$$\sigma_{PL} = \frac{P}{A} = \frac{75.4}{314.16} = 240 \text{ MPa}$$

1.34

The initial area of the test specimen was

$$A_0 = \pi D^2/4 = \pi (10)^2/4 = 78.54 \text{ mm}^2 \quad (a)$$

Since the reduction of area of the specimen is 55%, the area at fracture is, with Eq. (a),

$$A_F = (0.45) A_0 = 35.34 \text{ mm}^2 \quad (b)$$

Therefore, the true fracture stress is, with  $P = 43.2 \text{ kN}$  at fracture (see Table P1.31),

$$\sigma_t = \frac{43.2}{35.34} = 1220 \text{ MPa}$$

The engineering fracture stress is

$$\sigma_E = \frac{43.2}{78.54} = 550 \text{ MPa}$$

$$\text{The ratio } \sigma_E/\sigma_t = \left(\frac{550}{1220}\right)(100\%) = 45\%.$$

This result was to be expected, since the area at fracture is 45% of the original area

2.1

With  $\sigma_{xx} = 50 \text{ MPa}$ ,  $\sigma_{yy} = -30 \text{ MPa}$ ,  $\sigma_{zz} = 20 \text{ MPa}$ ,  
 $\sigma_{xy} = 5 \text{ MPa}$ ,  $\sigma_{xz} = -30 \text{ MPa}$ ,  $\sigma_{yz} = 0$ , and  $l = m = n = 1/\sqrt{3}$ ,  
 Eq. (2.10) yields

$$\sigma_{Px} = l\sigma_{xx} + m\sigma_{yx} + n\sigma_{zx} = \frac{1}{\sqrt{3}}(50 + 5 - 30) = 14.434 \text{ MPa}$$

$$\sigma_{Py} = l\sigma_{xy} + m\sigma_{yy} + n\sigma_{zy} = \frac{1}{\sqrt{3}}(5 - 30 + 0) = -14.434 \text{ MPa}$$

$$\sigma_{Pz} = l\sigma_{xz} + m\sigma_{yz} + n\sigma_{zz} = \frac{1}{\sqrt{3}}(-30 + 0 + 20) = -5.774 \text{ MPa}$$

then, by Eq. (2.11),

$$\begin{aligned} \sigma_{PN} &= l^2\sigma_{xx} + m^2\sigma_{yy} + n^2\sigma_{zz} + 2mn\sigma_{yz} + 2ln\sigma_{xz} + 2lm\sigma_{xy} \\ &= \frac{1}{3}[50 - 30 + 20 + 2(0) + 2(-30) + 2(5)] = -3.333 \text{ MPa} \end{aligned}$$

Therefore, by Eq. (2.12),

$$\sigma_{PS} = \sqrt{\sigma_{Px}^2 + \sigma_{Py}^2 + \sigma_{Pz}^2 - \sigma_{PN}^2} = \sqrt{(14.434)^2 + (-14.434)^2 + (-5.774)^2 - (-3.333)^2}$$

or

$$\sigma_{PS} = 20.950 \text{ MPa}$$

2.2

By Figure P2.2, the section cut off by  
 plane A-A is shown in Fig. b. By  
 equilibrium of forces,

$$\sum F_x = -\sigma(S \sin \theta) - \tau_0(S \cos \theta) - \tau_0 S (\cos \theta) = 0$$

$$\sum F_y = -\tau(S \sin \theta) + \tau_0 S (\sin \theta) = 0$$

Therefore,

$$\sigma = -2\tau_0 \cot \theta \text{ (compression)}$$

$$\tau = \tau_0$$

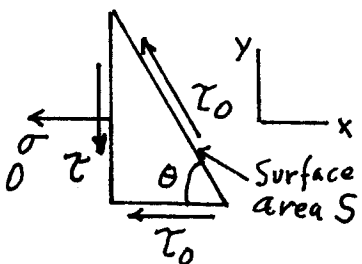

Figure a



2.3

(a) By Eqs. (2.21), with the given stress components,

$$I_1 = \sigma_{xx} = 20, \quad I_2 = -\sigma_{xz}^2 = -300, \quad I_3 = 0 \quad (a)$$

By Eqs. (a) and (2.20),  $\sigma^3 - 20\sigma^2 - 300\sigma = 0$ , or  
 $\sigma(\sigma - 30)(\sigma + 10) = 0$ . Hence,  $\sigma = 0, \sigma = 30, \sigma = -10$ .

Ordering the stresses, we have

$$\sigma_1 = 30 \text{ MPa}, \quad \sigma_2 = 0, \quad \sigma_3 = -10 \text{ MPa}$$

(b) With  $\sigma = \sigma_1$ , Eqs. (2.18) yield

$$(20 - 30)l + (0)m + 10\sqrt{3}n = 0 \Rightarrow l = \sqrt{3}n \quad (b)$$

$$-30m = 0 \Rightarrow m = 0 \quad (c)$$

$$10\sqrt{3}l + (0)m - 30n = 0 \quad (d)$$

where

$$l^2 + m^2 + n^2 = 1 \quad (e)$$

The solution of Eqs. (b), (c), and (e) is

$$l = \pm \sqrt{3}/2, \quad m = 0, \quad n = \pm 1/2 \quad (f)$$

Note that Eqs. (f) satisfy Eq. (d) identically.

2.4

(a) By Eq. (2.19) and the given stress components, the principal stresses are the roots of

$$\begin{vmatrix} (-100 - \sigma) & 0 & -80 \\ 0 & (20 - \sigma) & 0 \\ -80 & 0 & (20 - \sigma) \end{vmatrix} = 0$$

or

$$(20 - \sigma)(\sigma - 60)(\sigma + 140) = 0$$

Hence,  $\sigma_1 = 60 \text{ MPa}, \sigma_2 = 20 \text{ MPa}, \sigma_3 = -140 \text{ MPa} \quad (a)$

(Cont.)

2.4 cont.

(b) By Eqs. (2.22) and (a),

$$9\tau_{oct}^2 = (\sigma_1 - \sigma_2)^2 + (\sigma_1 - \sigma_3)^2 + (\sigma_2 - \sigma_3)^2 = 67200$$

or  $\tau_{oct} = 86.41 \text{ MPa}$  (b)

(c) By Eqs. (2.39) and (a),

$$\tau_{max} = \frac{1}{2}(\sigma_1 - \sigma_3) = 100 \text{ MPa} \quad (c)$$

By Eqs. (b) and (c),

$$\tau_{max} = 1.16 \tau_{oct}$$

(d) By Mohr's circle in the  $x$ - $z$  plane (Fig. a), the maximum shear stress occurs on planes for which  $2\theta_1 = 90^\circ$  (points P and P'); that is, on planes for which the direction cosines are  $(\pm \frac{1}{\sqrt{2}}, 0, \pm \frac{1}{\sqrt{2}})$ , relative to principal stress axes, and planes perpendicular to these planes (Fig. b).

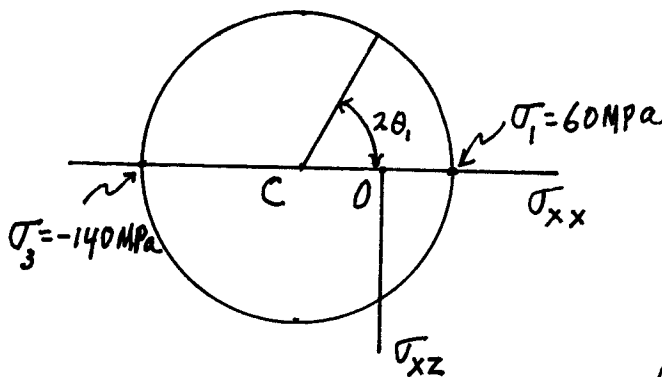

Figure a

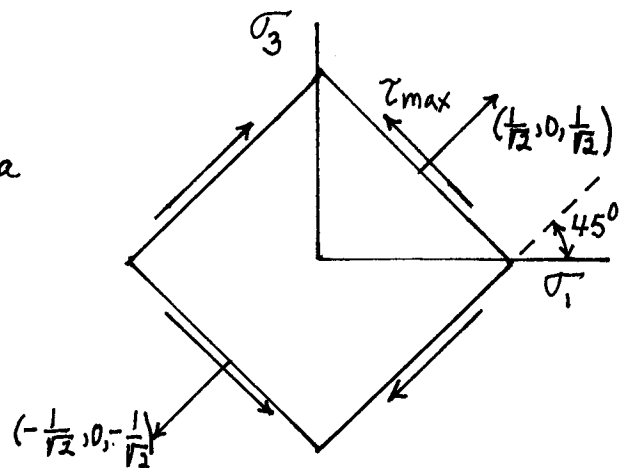

Figure b

2.5

(a) a unit vector in the direction of the vector  $\hat{i} + 2\hat{j} + \hat{k}$  has direction cosines

$$l = \frac{1}{\sqrt{6}}, m = \frac{2}{\sqrt{6}}, n = \frac{1}{\sqrt{6}} \quad (a)$$

Hence, by Eqs. (a) and (2.10) and the given stress components, the stress vector on the plane normal to the vector  $\hat{i} + 2\hat{j} + \hat{k}$  has components

$$\sigma_{Px} = l\sigma_{xx} + m\sigma_{xy} + n\sigma_{xz} = \frac{1}{\sqrt{6}}[80 + 2(20) + 40] = \frac{160}{\sqrt{6}}$$

$$\sigma_{Py} = l\sigma_{xy} + m\sigma_{yy} + n\sigma_{zy} = \frac{1}{\sqrt{6}}[20 + 2(60) + 10] = \frac{150}{\sqrt{6}} \quad (b)$$

$$\sigma_{Pz} = l\sigma_{xz} + m\sigma_{yz} + n\sigma_{zz} = \frac{1}{\sqrt{6}}[40 + 2(10) + 20] = \frac{80}{\sqrt{6}}$$

By Eqs. (b) and (2.9), the stress vector is

$$\underline{\sigma}_P = 65.32\hat{i} + 61.24\hat{j} + 32.66\hat{k}$$

(b) With the given stress components and Eqs. (2.21), the stress invariants are

$$I_1 = 80 + 60 + 20 = 160, I_2 = 5500, I_3 = 0 \quad (c)$$

By Eqs. (c) and (2.20),

$$\sigma^3 - 160\sigma^2 + 5500\sigma + 0 = 0$$

or

$$\sigma(\sigma^2 - 160\sigma + 5500) = 0 \quad (d)$$

The roots of Eq. (d) are

$$\sigma_1 = 110 \text{ MPa}, \sigma_2 = 50 \text{ MPa}, \sigma_3 = 0$$

(c) The maximum shear stress is

$$\tau_{\max} = \frac{1}{2}(\sigma_1 - \sigma_3) = 55 \text{ MPa}$$

(cont.)

2.5 cont. (d) The octahedral shear stress is given by

$$\tau_{oct}^2 = \frac{1}{9} [(\sigma_1 - \sigma_2)^2 + (\sigma_1 - \sigma_3)^2 + (\sigma_2 - \sigma_3)^2] = \frac{18200}{9}$$

or

$$\tau_{oct} = 44.97 \text{ MPa}$$

2.6

(a) Given

$$T = \begin{bmatrix} 4 & 1 & 2 \\ 1 & 6 & 0 \\ 2 & 0 & 8 \end{bmatrix} \quad (a)$$

By Eqs. (a) and (2.21), the stress invariants of T are

$$I_1 = 4 + 6 + 8 = 18$$

$$I_2 = \begin{vmatrix} 4 & 1 \\ 1 & 6 \end{vmatrix} + \begin{vmatrix} 4 & 2 \\ 2 & 8 \end{vmatrix} + \begin{vmatrix} 6 & 0 \\ 0 & 8 \end{vmatrix} = 99 \quad (b)$$

$$I_3 = \begin{vmatrix} 4 & 1 & 2 \\ 1 & 6 & 0 \\ 2 & 0 & 8 \end{vmatrix} = 160$$

(b) The 45° rotation of axes (x, y) is shown in Fig. a.

The direction cosines are given in Table a. Then,

by Eqs. (a) and (2.15), with Table a,

$$\begin{aligned} \sigma_{xx} &= \left(\frac{1}{\sqrt{2}}\right)^2(4) + \left(\frac{1}{\sqrt{2}}\right)^2(6) + (0)(8) \\ &\quad + 2\left(\frac{1}{\sqrt{2}}\right)(0)(0) + 2(0)\left(\frac{1}{\sqrt{2}}\right)(2) \\ &\quad + 2\left(\frac{1}{\sqrt{2}}\right)\left(\frac{1}{\sqrt{2}}\right)(1) = 6 \text{ MPa} \end{aligned}$$

Similarly,

$$\sigma_{yy} = 4 \text{ MPa}, \quad \sigma_{zz} = 8 \text{ MPa}$$

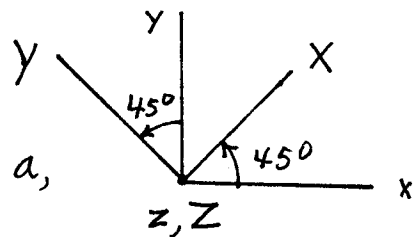

Figure a

Table a	x	y	z
x	$1/\sqrt{2}$	$1/\sqrt{2}$	0
y	$-1/\sqrt{2}$	$1/\sqrt{2}$	0
z	0	0	1

(cont.)